

ISL55187 EVM Getting Started

Rev A03 : 1-27-05



This document contains information on a product under development. The parametric information contains target parameters that are subject to change.

Table of Contents

1	Introduction	4
1.1	Unpacking - ISL55187 EVM Contents	4
1.2	Recommended Test and Measurement Setup	4
1.2.1	Power Supply	4
1.2.2	PC Controller	4
1.2.3	DMM or Source Measurement Unit	4
1.3	Software Installation	5
1.3.1	ISL55187 EVM UIP Installation	5
1.3.2	Parallel Port (ParPort2K) Installation	5
1.3.3	Reboot Machine	5
1.3.4	Launching the ISL55187 EVM Program	5
1.3.5	Software Un-Installation	5
2	Getting Started	6
2.1	Default Configuration Setup Options	6
2.2	Quick Start Instructions	8
2.3	Motherboard Jumper Definition	9
2.4	ISL55187 Menu Dialog Boxes	10
2.5	Evaluating Channel #1 or a Different Ext-DAC	11
2.5.1	Evaluate Channel #1	11
2.5.2	Evaluate a Different Ext-DAC	11
2.6	DC Pin Driver Configuration	12
3	ISL55187 Loadboard Detailed Description	13
3.1	Resistor Network Definitions	14
3.2	ADC and Analog Mux	14
3.3	Controller Logic	15
4	Document Revision History	17

List of Figures

Figure 1:	Installation Directory Structure	5
Figure 2:	ISL55187 EVM Simplified Block Diagram	7
Figure 3:	Expected Current Readings	8
Figure 4:	Device Config Menu Options	10
Figure 5:	ISL55187 DC Pin Driver Configuration Block Diagram	12
Figure 6:	ISL55187 EVM Detailed Block Diagram	13
Figure 7:	ISL55187 EVM Resistor Network Block Diagram	14
Figure 8:	ISL55187 EVM: Controller Section Detailed Block Diagram	15

List of Tables

Table 1:	ISL55187 EVM Contents	4
Table 2:	Power Supply Requirements	4
Table 3:	ISL55187 Default Configuration Options	6
Table 4:	Motherboard SMA & Jumper Definitions	9
Table 5:	FVMI Analog Mux – VINPOS(A) & VINNEG(A) Mapping	14
Table 6:	Loadboard C-Bit (J6) Signal Definitions	15

Table 7: STB_I (U8: ISL55187 AMUX & SEL) Signal Definitions 15
Table 8: STB_J (U9: ISL55187 Connect PMU/VForce Switches) Signal Definitions 16
Table 9: STB_K (U10: ISL55187 LOAD#_SEL) Signal Definitions 16
Table 10: STB_L (U6: ISL55187 LOAD#_SENSE) Signal Definitions 16
Table 11: STB_M (U16: ISL55187 Connect Ext DAC[12-9] to GND) Signal Definitions 16

1 Introduction

Congratulations on your purchase of a Elevate Semiconductor ISL55187 EVM evaluation system. You will find that it serves as an invaluable development platform to help get your product to market in the shortest possible time. The ISL55187 EVM and Graphical User Interface (GUI) allow the customer to demonstrate and evaluate the ISL55187 performance and functionality.

This document provides the instructions to install, setup, and operate the ISL55187 EVM. Refer to the *Elevate Semiconductor EVM User's Guide* for a detailed description of the EVM system.

1.1 Unpacking - ISL55187 EVM Contents

Please check the contents of the ISL55187 EVM shipping carton to make sure you have received all of the items listed in Table 1. The system is already configured for the best setup, except for connections to the power supply, PC controller, and test equipment.

Table 1: ISL55187 EVM Contents

Qty	Description
1 ea.	ISL55187 EVM System (3 boards)
1 ea.	ISL55187 EVM Getting Started (this document)
1 ea.	Elevate Semiconductor User Interface Program Installation CD
1 ea.	DB25M-DB25M, 6 Foot Parallel Port Cable

1.2 Recommended Test and Measurement Setup

1.2.1 Power Supply

Table 2 provides the required power supplies and current rating. The power supplies are connected using standard banana plugs. The customer needs to provide the power supply cables.

Table 2: Power Supply Requirements

Supply	Current Rating
+20V	0.5 A
+5V	1.0 A
-15V	0.5 A

1.2.2 PC Controller

To use the ISL55187 EVM User Interface Program (UIP), a PC with the following configuration is required:

- Win98, Win2000, WinNT 4.0+, or Win XP
- Parallel/Printer Port – 25-pin female connector

1.2.3 DMM or Source Measurement Unit

- Voltage and/or Current Meter
- Voltage and/or Current Source

1.3 Software Installation

There are 2 steps to install the ISL55187 EVM demonstration program.

1. Install the ISL55187 EVM UIP from the CD-ROM.
2. Install the parallel port driver (ParPort2k).

Figure 1 illustrates the default directory structure. The user may change the <root dir> during the installation.

Figure 1: Installation Directory Structure

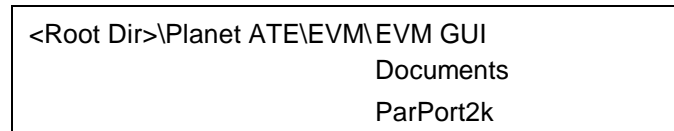

1.3.1 ISL55187 EVM UIP Installation

To install the ISL55187 EVM software package, run the SETUP program on the distribution CD and follow the prompts. The **PlanetATE.exe** executable will be installed in the **EVM GUI** sub-directory. In addition, a short cut will be installed onto the desktop and in the **Start->Programs** folder. The **Start->Programs** folder also contains links to the different product datasheets, EVM User's Guide, and documentation folder.

1.3.2 Parallel Port (ParPort2K) Installation

To install the ParPort2K parallel port driver, run the **setup.exe** from the **ParPort2k** sub-directory after the main installation is complete and click the **Install** button. For WinNT users, the user must have administration rights.

Note: ParPort2k is a copyright of Zeecube Software.

1.3.3 Reboot Machine

After the ISL55187 EVM and Parallel Port software is installed, it is recommended to re-boot the machine.

1.3.4 Launching the ISL55187 EVM Program

The user can launch the ISL55187 EVM GUI from the desktop, **Start->Programs** folder, or **EVM GUI** sub-directory.

1.3.5 Software Un-Installation

The ISL55187 EVM demonstration program may be un-installed using the **Add/Remove Program** from the Windows Control Panel.

2 Getting Started

The ISL55187 EVM is shipped in a pre-configured state that allows a customer to evaluate the PMU Force Voltage (FV) / Force Current (FI), Ganging, and Ext-DACs.

Note: Any external equipment providing digital signals into ISL55187 should only be enabled after the ISL55187 EVM is enabled. Also, the external equipment should be disabled prior to disabling the ISL55187 EVM.

2.1 Default Configuration Setup Options

The EVM has several default options for providing a DATA stream and/or configuring for PMU mode.

Table 3: ISL55187 Default Configuration Options

Mode	Brief Description
Hardware Reset	All registers default to the hardware default state.
Three-State (High-Z)	Puts PMU in three-state (high-Z). Opens all switches.
FV Chan #0	Ch#0 FV mode outputting 1.5V, Irange=2mA, LOCAL sense feedback. FORCE #0 pin connected to the EVM PMU_EXT_F SMA. EVM Amux-F connects PMU_EXT_F back to SENSE #0 pin for optional remote sense. MONITOR is enabled and setup to measure Ch#0 MV voltage
FI Chan #0	Ch#0 FI mode outputting 0.0uA, Irange=2mA FORCE #0 pin connected to the EVM PMU_EXT_F SMA. EVM Amux-F connects PMU_EXT_F back to SENSE #0 pin for remote voltage measurements. MONITOR is enabled and setup to measure Ch#0 MV voltage
Ganging	Ch#0 FV mode outputting 1.5V, Irange=32mA, remote sense feedback. Ch#1 FI mode sourcing from MI #0, Irange=32mA FORCE #0 pin connected to the EVM PMU_EXT_F SMA. PMU-F #1 connected to FORCE #0 pin (internal ganging) EVM Amux-F connects PMU_EXT_F back to SENSE #0 pin for remote sense. MONITOR is enabled and setup to measure Ch#0 MV voltage
Ext-DAC	Ch#0 Ext-DAC #0 output 2.0V. GND Force disabled. Ch#0 DAC #0 pin connected to EVM Amux-F then to PMU_EXT_F SMA.
DC Pin Driver	See Section 2.6

Figure 2 illustrates the recommended configuration for ISL55187 EVM evaluation. The external measurement unit (MU) should be configured in the opposite mode as ISL55187. After the configuration is completed, use the **PMU FV/FI Levels** dialog box the change the ISL55187 output levels.

ISL55187	MU
FVMI	FIMV
FIMV	FVMI

Figure 2: ISL55187 EVM Simplified Block Diagram

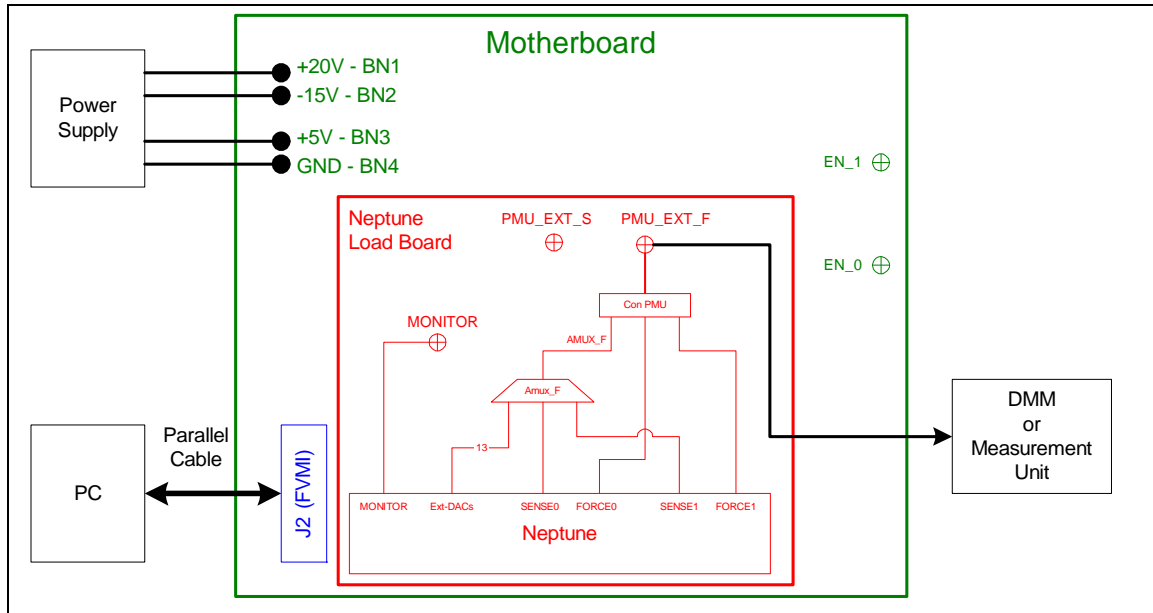

2.2 Quick Start Instructions

1. Disable external power supply
2. Connect the power supplies cables (not provided) from the power supply to the Elevate Semiconductor EVM Motherboard.
3. Connect the parallel cable (provided) from the PC to J2 on the Octal FVMI board.
4. Connect the EVM to any external equipment; refer to Section 2.1.
5. Setup Motherboard Jumpers; refer to Section 2.3
6. Set external power supply voltages and current limits.
7. Enable external power supply.
8. Run the Elevate Semiconductor GUI software; refer to Section 1.3.4 for details.
9. At the Force Voltage – Measure Current dialog box (refer to Figure 3 below):
 - a. Select the **EVM Setup** option based on the desired configuration.
 - b. Select the **Enable Supplies** check box
 - c. Hit the **Apply** button to power up the ISL55187 device.
 - d. The software will also measure the current consumption. Figure 3 illustrates the expected current readings.
10. At this point, the ISL55187 should be outputting the desired signal.

Figure 3: Expected Current Readings

The screenshot shows the 'Force Voltage - Measure Current (FVMI) Configuration' dialog box. It includes a 'Revision' section (V100 EVM, S/N = 12), a 'Reset System' button with a warning, and 'PLL Freq (MHz)' settings (PLL_CK: 100.000, Apply PLL_CK, PLL Present, CAP_PLL = VOH). Under 'Device Options', 'EVM Setup' is set to 'PMU-FV' (with a dropdown menu open showing options like Hardware Reset, Three-State (High-Z), PMU-FV, PMU-FI, Ganging, and Ext DACs). The 'Enable Supplies' checkbox is checked. The 'Power Amplifier' section contains a table with columns for Channel, Voltage, Current (mA), and Power (mW). A 'Measure' button is present. At the bottom, there is a 'Perform Range Check' checkbox and a 'Total Power' field showing 512.9.

Channel	Voltage (V)	Current (mA)	Power (mW)
Chan 1 (VFD) (-8.0 to +15.0)		2.3	0.0
Chan 2 (VCC) (+6.0 to +15.0)	13.000	27.8	361.4
Chan 3 (VDD) (0.0 to +5.0)	3.300	21.5	70.9
Chan 4 (VEE) (-5.0 to +0.0)	-3.000	-24.5	73.4
Chan 5 (VOH) (+1.0 to +3.3)	2.000	1.1	2.2
Chan 5 (-0.5 to +1.0)	0.000	1.6	0.0
Chan 6 (+2.5 to +3.5)	3.000	1.7	5.1
Total Power			512.9

The **Reset System** will put the EVM and ISL55187 device into the default state. The **Reset System** should be issued whenever the power supply is powered OFF then ON. The **Reset System** is automatically performed when the program is initially launched.

2.3 Motherboard Jumper Definition

Table 4 lists the Motherboard Jumper definitions for the ISL55187 EVM.

Table 4: Motherboard SMA & Jumper Definitions

ISL55187 EVM	Jumper	Configuration
N/A	E12	
N/A	E11	
SDI_DATA	E14	Short Pin 1 & 2. Toward back of board
SDI_SCK	E15	Short Pin 1 & 2. Toward back of board
SDI_RCK	E2	Short Pin 1 & 2. Toward back of board
EN_C0_S_MUX	E10	Short Pin 1 & 2. Toward back of board
EN1	E9	As desired.
EN_C1_F_MUX	E8	Short Pin 1 & 2. Toward back of board
N/A	E7	
N/A	E1	
EN_C1_S_MUX	E6	Short Pin 1 & 2. Toward back of board
EN0	E5	As desired.
COMP_IN	E4	Short Pin 1 & 2. Toward back of board
EN_C0_F_MUX	E3	Short Pin 1 & 2. Toward back of board
N/A	E13	
N/A	E20	

2.4 ISL55187 Menu Dialog Boxes

Figure 4 illustrates the ISL55187 menu options. These provide access to the ISL55187 registers.

Figure 4: Device Config Menu Options

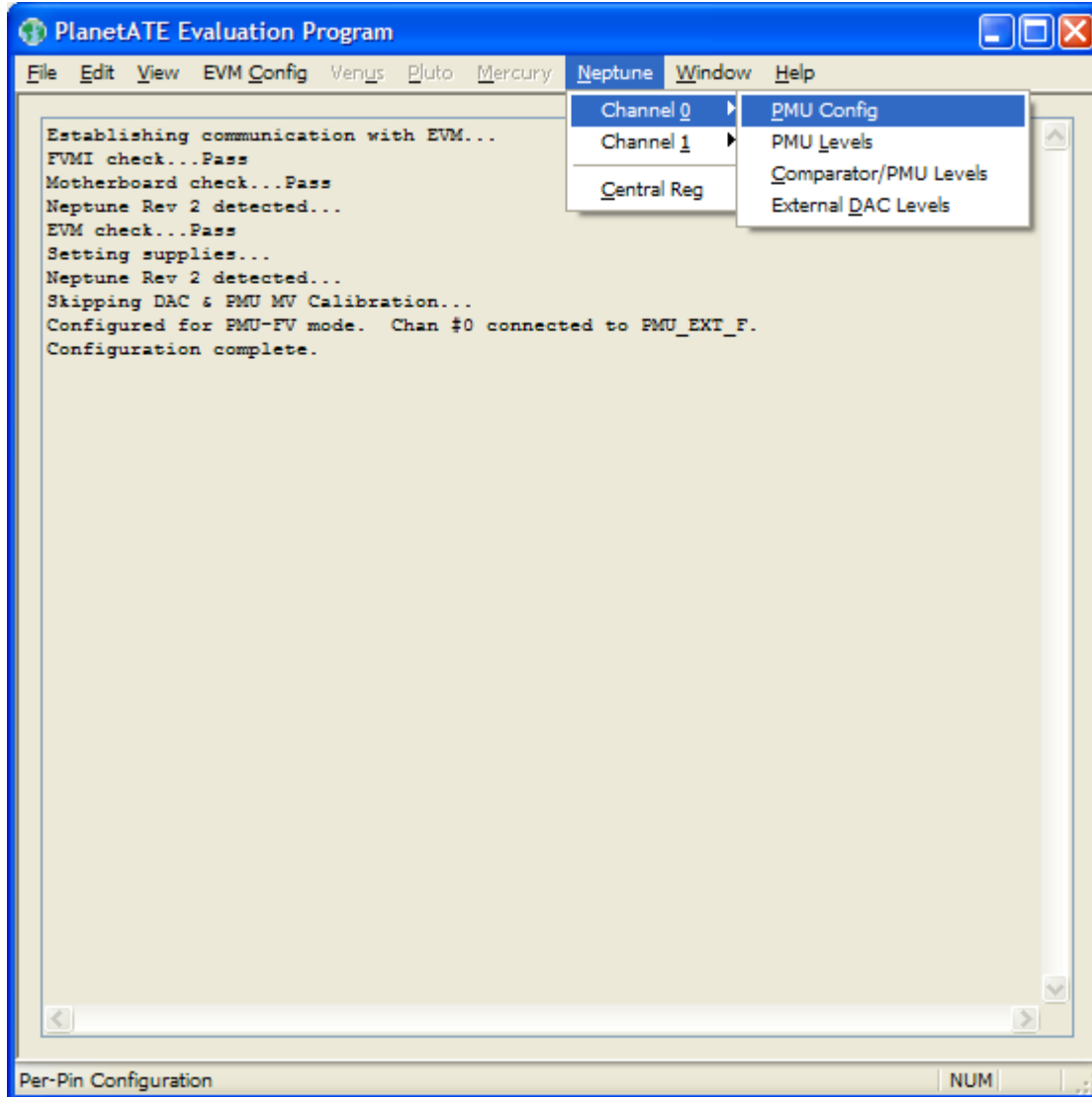

2.5 Evaluating Channel #1 or a Different Ext-DAC

The ISL55187 EVM only supports evaluating one channel/Ext-DAC at a time. Use the following instructions to configure the ISL55187 EVM for Channel #1 or another Ext-DAC

2.5.1 Evaluate Channel #1

- Start with the FV or FI Default Configuration, see Section 2.1. This will program both channels to the specified configuration but only connects Channel #0 to the PMU_EXT_F SMA.
- From the main menu, select the **EVM Config->ISL55187 EVM Config** dialog box:
 1. Within the **Con PMU_EXT_F** group:
 - Unselect the **FORCE #0** check box
 - Select the **FORCE #1** check box
 - Leave the **AMUX-F** box selected
 2. Select the **SENSE #1** option from the **AMUX Select** pull-down menu
 3. Hit **Apply** to write the EVM configuration
- At this point, the Channel #1 output can be measured at the PMU_EXT_F SMA

2.5.2 Evaluate a Different Ext-DAC

- Start with the Ext-DAC Default Configuration, see Section 2.1. This will program both channels to the specified configuration but only connects Channel #0 Ext-DAC #0 to the PMU_EXT_F SMA.
- From the main menu, select the **EVM Config->ISL55187 EVM Config** dialog box:
 1. Select the desired Ext-DAC (either channel) option from the **AMUX Select** pull-down menu
 2. Leave the **AMUX-F** check box selected in the **Con PMU_EXT_F** group
 3. Hit **Apply** to write the EVM configuration
- At this point, the desired Ext-DAC output can be measured at the PMU_EXT_F SMA

2.6 DC Pin Driver Configuration

The DC Pin Driver configuration uses the PMU-FV (high) and EXT_FORCE (low) to create DC pin driver. The EXT_FORCE is sourced from the EVM VFORCE supply (FVMI board); the default is 0.0V. The Con-PMU and Con-EF-F switches are configured for real-time operation. The EN signal is used to toggle the DC pin driver between the FV (high) and EXT_FORCE (low) state.

The Fmax is about 4-5 MHz.

Setup (refer to Figure 5):

- Connect a scope to the PMU_EXT_F SMA.
- Select the **DC Pin** option from the **EVM Setup** menu (found in **ISL55187->Central Reg**)
- Move the E5 jumper (EN_0) between pins 2 & 3 (towards the ISL55187 device)
- Connect a single ended pulse generator to the EN_0 SMA on the motherboard

Note: The pulse generator must be disabled whenever the ISL55187 device is powered down.

Figure 5: ISL55187 DC Pin Driver Configuration Block Diagram

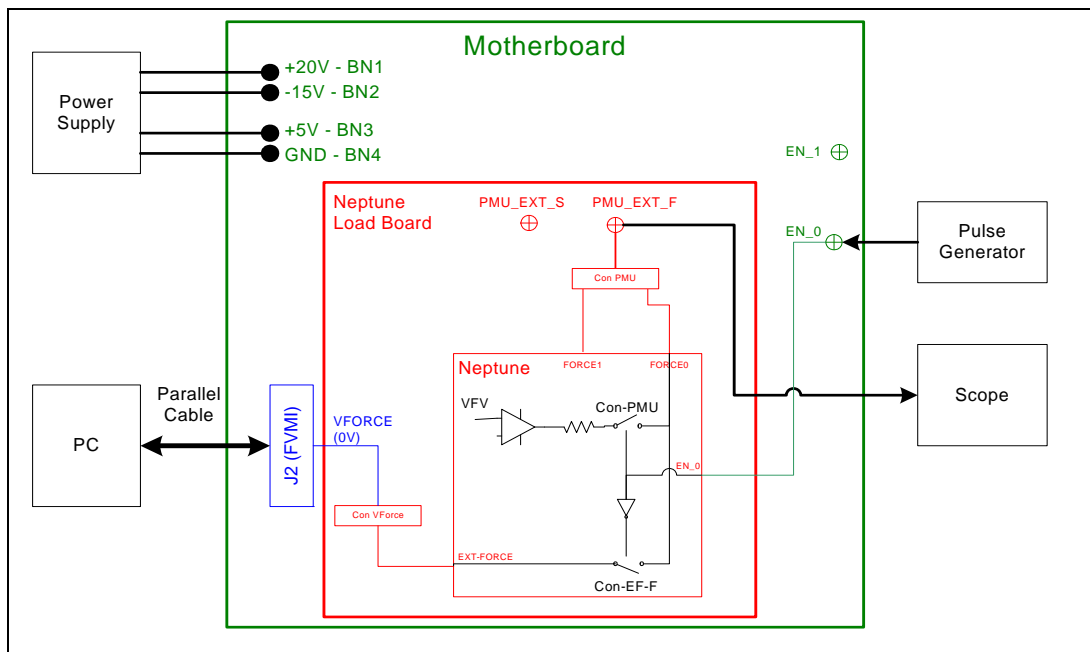

The following lists the ISL55187 register and EVM configuration for the DC Pin application:

- Set ISL55187 PMU to VR1, VFV=5V, Tight Loop, IR=32mA
- Set ISL55187 Con-PMU to real-time control: Sel-PPMU-Con = 1
- Set ISL55187 Con-EF-F to real-time control: Sel-Con-EF-F = 1
- Set EVM Con-PMU to FORCE_0
- Set EVM Con-VFORCE to Ext-Force, set VFORCE=0V
- All other non-pertinent ISL55187 and EVM switches are left open

3 ISL55187 Loadboard Detailed Description

Figure 6 illustrates the ISL55187 EVM loadboard. The loadboard contains the ISL55187 device as well as the necessary circuitry to validate & characterize on the bench environment.

Figure 6: ISL55187 EVM Detailed Block Diagram

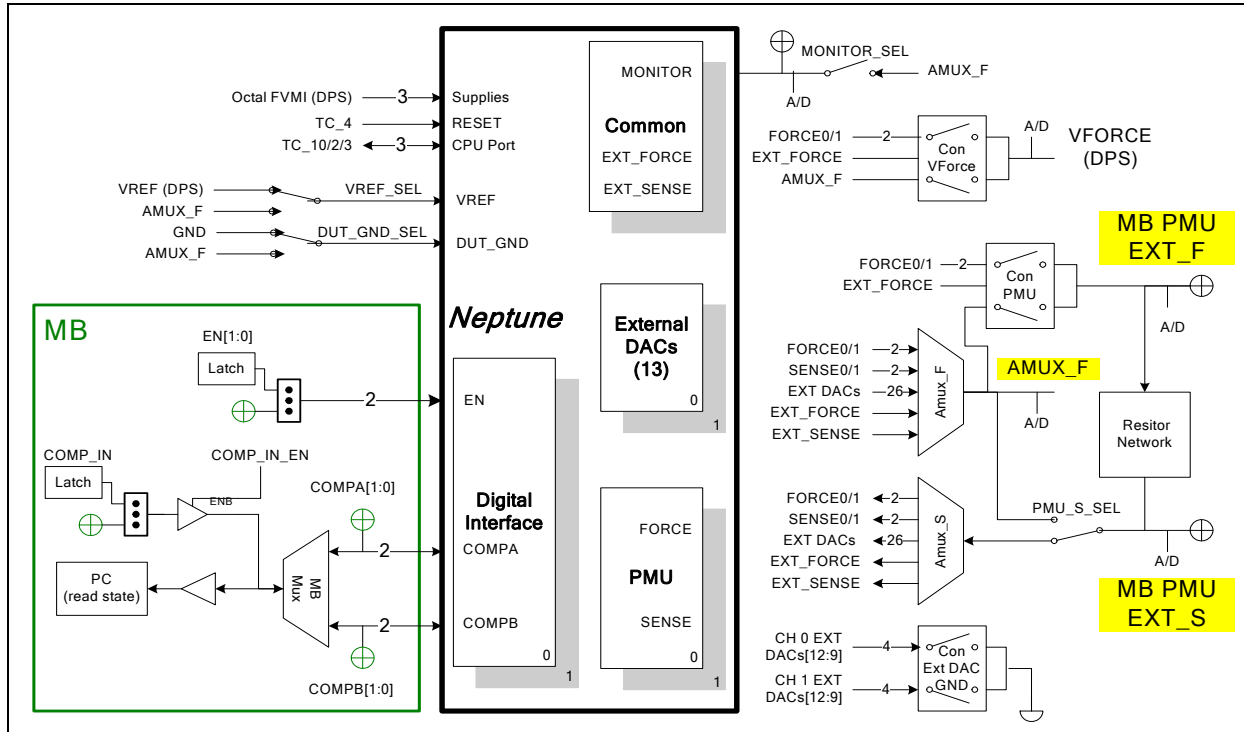

3.1 Resistor Network Definitions

Figure 7 illustrates the ISL55187 EVM resistor network definitions. The software only allows a single resistor value to be switched in.

Figure 7: ISL55187 EVM Resistor Network Block Diagram

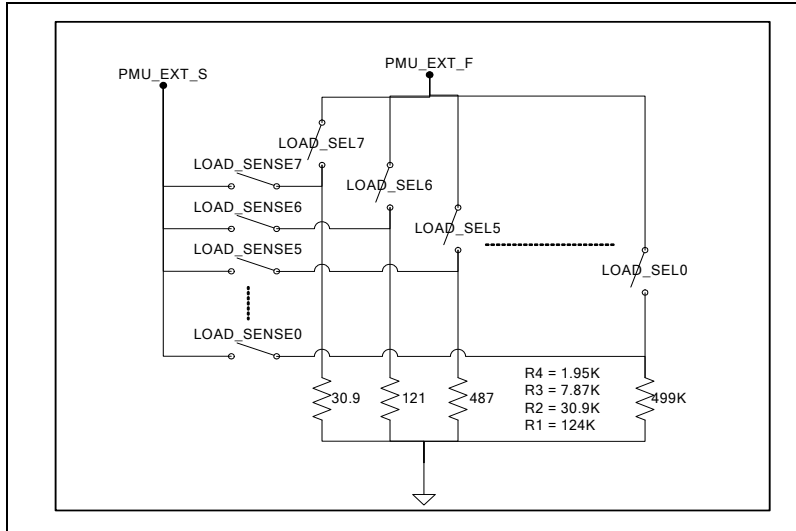

3.2 ADC and Analog Mux

The Octal FVMI contains a 24-bit ADC and analog muxes. **Table 5** lists the ISL55187 EVM loadboard specific mux input sources.

Table 5: FVMI Analog Mux – VINPOS(A) & VINNEG(A) Mapping

Addr	VINP#	VINPOS(A)	VINN#	VINNEG(A)
7	VINP8	Reserved	VINN8	No connect
8	VINP9	MB_PMU_EXT_F	VINN9	No connect
9	VINP10	AMUX_F	VINN10	No connect
10	VINP11	MONITOR	VINN11	No connect
11	VINP12	MB_PMU_EXT_S	VINN12	No connect
12	VINP13	TC-31 (N/C)	VINN13	No connect
13	VINP14	TC-32 (N/C)	VINN14	No connect

3.3 Controller Logic

The ISL55187 loadboard contains five 8-bit latches (registers) and a 16K EEPROM. The Cbit1 to CBit7 are also used to control various relays; the C-Bits originate from the Octal FVMI board. Figure 8 illustrates the Pluto EVM controller section.

Figure 8: ISL55187 EVM: Controller Section Detailed Block Diagram

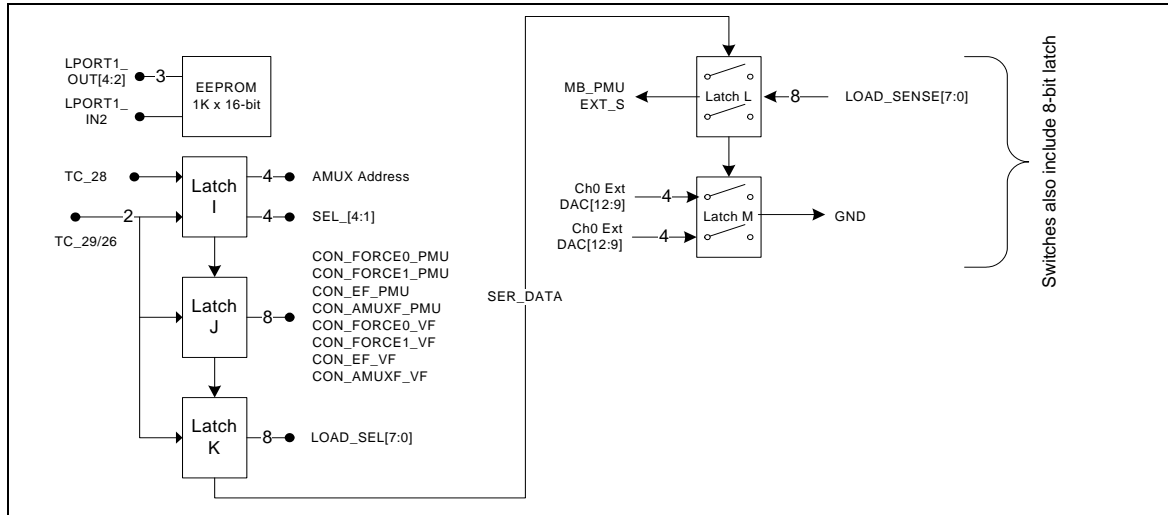

Table 6: Loadboard C-Bit (J6) Signal Definitions

CBIT#	Def	Bit Name	Bit Description
7:1	0	CBIT[7:1]	Unused
8	-	Reserved	Used by ATE test board
9	-	Reserved	Used by Octal FVMI board

The latches are daisy chained together using the SDI_SCK/RCK/CS signals originating from the Motherboard. The EEPROM is controlled by the LPOR1_OUT[4:2] signals originating from the motherboard. The loadboard latches are labeled STB_I to STB_P. This was named as an extension to the REG_A to REG_H Octal FVMI / Motherboard registers.

Table 7: STB_I (U8: ISL55187 AMUX & SEL) Signal Definitions

STB_I Bit	Bit Name	Bit Description
3:0	AMUX	Analog MUX 15 – 0 = Ch DAC 0 – 12, Force, Sense, Ext-Force/Sense
4	SENSE_SEL	PMU_S_SEL Select 0 = AMUX_S 1 = AMUX_F
5	DUT_GND_SEL	DUT_GND Select (SEL_2) 0 = GND 1 = AMUX_F
6	MONITOR_SEL	MONITOR Select (SEL_3) 0 = VINP11 (to A/D) 1 = AMUX_F
7	VREF_SEL	VREF Select (SEL_4) 0 = VREF (DPS) 1 = AMUX_F

Table 8: STB_J (U9: ISL55187 Connect PMU/VForce Switches) Signal Definitions

STB_J Bit	Bit Name	Bit Description
3:0	CON_PMU	Connect PMU EXT F to : 0 or -1 (EVM_OPEN_ALL) = Open All 0x01 (ISL55187_CON_F0_PMU) = FORCE0 0x02 (ISL55187_CON_F1_PMU) = FORCE1 0x04 (ISL55187_CON_EF_PMU) = Ext-Force 0x08 (ISL55187_CON_AMUX_F_PMU) = AMUX_F Bit-weighted, can set more than one at a time
7:4	CON_VFORCE	Connect VFORCE to : 0 or -1 (EVM_OPEN_ALL) = Open All 0x01 (ISL55187_CON_F0_VFORCE) = FORCE0 0x02 (ISL55187_CON_F1_VFORCE) = FORCE1 0x04 (ISL55187_CON_EF_VFORCE) = Ext-Force 0x08 (ISL55187_CON_AMUX_F_VFORCE) = AMUX_F Bit-weighted, can set more than one at a time

Table 9: STB_K (U10: ISL55187 LOAD#_SEL) Signal Definitions

STB_K Bit	Bit Name	Bit Description
7:0	LOAD[7:0]_SEL	Connect PMU_EXT_F to Current Resistor #

Table 10: STB_L (U6: ISL55187 LOAD#_SENSE) Signal Definitions

STB_K Bit	Bit Name	Bit Description
7:0	LOAD[7:0]_SENSE	Connect PMU_EXT_S to Current Resistor #

Table 11: STB_M (U16: ISL55187 Connect Ext DAC[12:9] to GND) Signal Definitions

STB_K Bit	Bit Name	Bit Description
3:0	CON_CH0_DAC_GND	Connect Channel 0 Ext-DAC [12:9] to GND. Bit weighted, can OR more than one together. Use 0x00 to open all. CON_DAC9_GND (0x08) CON_DAC10_GND (0x04) CON_DAC11_GND (0x02) CON_DAC12_GND (0x01)
7:4	CON_CH1_DAC_GND	Connect Channel 1 Ext-DAC [12:9] to GND. Bit weighted, can OR more than one together. Use 0x00 to open all. CON_DAC9_GND (0x08) CON_DAC10_GND (0x04) CON_DAC11_GND (0x02) CON_DAC12_GND (0x01)

4 Document Revision History

Revision	Date	Description
A01	10/18/03	Initial Draft
A02	1/24/04	Added DC Pin Driver configuration, see Section 2.6
A03	1/27/05	Added Detailed Block Diagram, see Section 3 <ul style="list-style-type: none">• Moved from 'Elevate Semiconductor User's Guide'• Added Resistor Network block diagram, see Section 3.1• Added Controller Logic block diagram, see Section 3.3